



VIGOR PRECISION LTD.

力嘉精密有限公司

VS-10A SERVO

FOR REFERENCE

TECHNICAL DATA

Control System:	Pulse width control, 1500µs neutral	
Operating Voltage:	4.8V~6.0V (DC)	
STD Direction:	Counter clockwise/pulse traveling 800 to 2200 µsec.	
Test Voltage:	at 4.8V	at 6.0V
Operating Speed:	0.23sec/60° at no load	0.20sec/60° at no load
Stall Torque:	≥7.5kgf.cm(104.15oz/in)	≥9.0kgf.cm(124.98oz/in)
Running Current:	~0.25A	~0.30A
Stall Current:	~2.6A	~3.3A
Output Angle:	≥170°	
Dead Band Width:	5µsec	

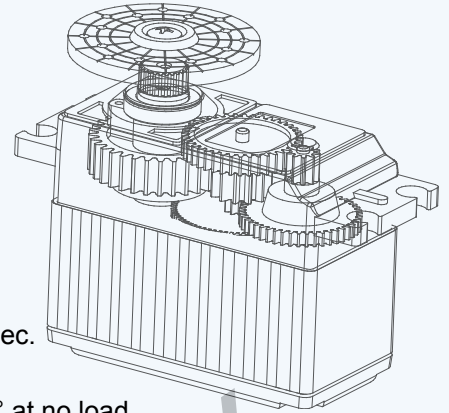

FEATURES

Motor Type:	3poles metal brush motor (Normal Motor)
Potentiometer Life:	1,000,000 cycles
Bearing:	2pcs Ball bearing
Gear Material:	Resin and Heavy Duty Resin
Spline Horns:	Spline type for FUTABA style
Connector Wire Length:	250mm(9.84in),22AWG(Connector for FUTABA or JR style)
Other Features:	Heat Sink(Aluminium middle case),Water Resistance

DIMENSIONS

Size :	49.2×25×42.5mm(2.54×1.0×1.67in)
Weight:	60g (2.12 oz)

CASE AND HORN DRAWING

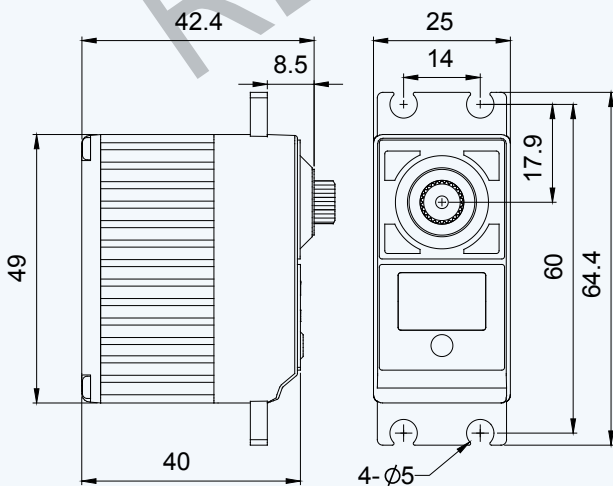

- STD ACCESSORIES:** Horn Screw × 1pc
 Cross Horn "D" × 1pc
 Star Horn "D" × 1pc
 Circular Horn "D" × 1pc

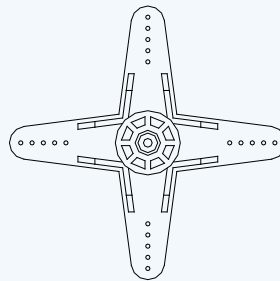

Cross Horn "D"

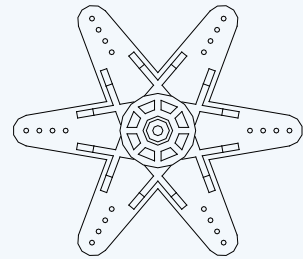

Star Horn "D"

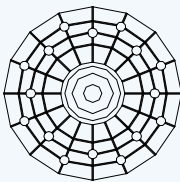

Circular Horn "D"

OPTION ACCESSORIES:

Servo Mounter "Set-A": Rubber Mounter × 4pcs and Metal Sleeve × 4pcs

REMARKS:

